



TECNO
CANAPA
NATURAL BUILDING



PRODUCT CATALOGUE



NEW
CONSTRUCTION



ENERGY EFFICIENCY
AND RENOVATION



RENDERS
AND FINISHES



INDEX

TECNOCANAPA SENINI	04
BUILD THE FUTURE	06
HEMP AND LIME	08
GREEN BUILDING	10
THE HOUSE THAT BREATHEES	12
NEW CONSTRUCTION	14
PERIMETER WALLS AND PARTITIONS	15
ROOFS AND SUBFLOORS	16
FLOOR SLABS	18
ENERGY EFFICIENCY AND RENOVATION	20
COUNTER WALLS	21
ROOFS AND SUBFLOORS	23
EXTERNAL INSULATION SYSTEMS	25
RENDERS AND FINISHES	26
THERMAL HEMPCRETE RENDERS	27
HEMPCRETE-BASED TEXTURED CYCLES	28
MINERAL CIVIL FINISHING CYCLES	29
TECHNICAL DATA SHEETS	30
INSULATING MATERIALS	31
BIOMATTONE®	31
MALTA E CANAPA	32
MALTA PRONTA	33
BIO BETON® PRONTO	34
CANAFIBER CAPPOTTO	35
CANAFIBER INTERCAPEDINE	36
BULK PRODUCTS TO BE MIXED	37
CANAPULO GROSSO	37
CANAPULO FINE	38
POLVERE DI CANAPA	39
LEGANTE DOLOMITICO	40
ADDITIVO PROBIOTICO	41
RENDERS AND FINISHES	42
BIO BETON® 500 VENEZIA	42
INTONACO E CANAPA	43
CANAPULINO®	44
CANAPOSO®	45
INTONACO DI CALCE NATURALE	46
STABILITURA NATURALE TRASPIRANTE PLUS	47
MALTA FINE	48
REALISATIONS	49

TECNO CANAPA SENINI



Eco-sustainable

healthy, beautiful, on a human scale

TECNOCANAPA

A choice that keeps up with the times, coherent with the strategy of the company that for many years, has been engaged in the production of innovative and eco-sustainable materials.

The houses of the future will increasingly be built with natural materials: a fast-growing trend that contributes to preserve the environment and ensure a better quality of life for everyone. Attention and sensitivity that have always been part of us; that is why we want to offer a product with enormous potential, with an important and credible past, rediscovered, innovated and intended to become the protagonist of new buildings "

Massimo Senini

Lavoriamo per il benessere dell'Uomo e dell'Ambiente®



BUILD DIFFERENTLY

Tecnocanapa is a complete range of solutions for the building envelope consisting of natural and sustainable materials that provide high level of energy efficiency and healthiness. These innovative materials fully meet the requirements of sustainable development: minimising the environmental impact during the production phase of the building material, during its implementation and for the entire lifetime of the building.

TECHNICAL PERFORMANCE AND ENVIRONMENTAL SUSTAINABILITY



BUILD THE FUTURE



HEMP & LIME

Building materials of the Third Millennium



Industrial production

Natural resources



Scientific research



The new range of products in hemp and lime represent the future of the building industry because these materials are natural, sustainable and energy efficient. Our company owns the largest manufacturing plant of Italy entirely dedicated to the production of hemp and lime biocomposites. The industrial approach allows us to ensure quality and competitiveness keeping up with the pace of the increasingly pressing challenges of the construction sector.

THE USE OF HEMP FOR CONSTRUCTIONS IS REALLY ANCIENT.

A recent study carried out in India at Babasaheb Ambedkar Marathwada University showed that a mixture of hemp, lime and clay used as a coating inside the Ellora caves in Aurangabad (Unesco world heritage site) allowed to maintain stable conditions of humidity in order to protect paintings for over 1500 years.

Its long-lasting characteristics were already known 1500 years ago. It has been confirmed by the discovery of many examples of centenary works. Amongst others, a bridge built 1500 years ago with a conglomerate of hemp and lime has been found by archaeologists in the south of France.



LIME IS A TRADITIONAL MATERIAL, PROTAGONIST OF THE EVOLUTION OF CONSTRUCTION AND ARCHITECTURE.

The oldest known artifact made with lime dates back to 7000 BC. Lime is obtained by heating limestone, a rock that is abundantly found in nature. Natural lime has a very long life cycle and can be considered as the building binder of the third millennium due to its intrinsic characteristics of breathability, healthiness and resistance for buildings. The use of the composite by peoples and civilisations throughout history is proof of the constructive value of lime and hemp, supported today by the scientific recognition of universities and research centers in Italy, France, United States, Canada, Germany and England.



HEMP & LIME

The mixture of hemp, water and lime creates an ideal product for use in natural building.

The high silica content of hemp shiv - the woody part of the plant - combined to the magnesium of the natural lime, activates the carbonation of the material and the hardening of the fibres. Once the composite is dried, it becomes rigid, very resistant and durable while being light and elastic.



European Patent
EP3121156B1



HEMP SHIV
the woody part of the hemp
plant

+



STRUCTURED
INFORMED WATER

+



PROBIOTICS

+



LIME
Natural binder



THE EVAPORATION OF WATER CAUSES A CHANGE OF STATE.
The lime mineralises
the vegetable component of the hemp shiv.

» MINERAL

The composite consolidates within a few hours and this petrification process keep going until it acquires a consistency similar to stone.



» APPLICATIONS

The blocks of hemp and lime, combined with a load-bearing structure in wood, steel or reinforced concrete, can be used for different structural and thermal purposes whether for private, commercial or industrial construction.

The perimeter wall made of hemp and lime does not require cladding panels, insulating panels or vapour barriers.

» IT IS USED FOR:

- Building up new perimeter walls
- Carrying out lightened and insulated bio-slabs
- Recovery building: renovations and restorations
- Interventions of thermal insulation for existing buildings

SIMPLE materials, employed for **CENTURIES**, combined to the **TECHNOLOGY** for

GREEN BUILDING



ECO-FRIENDLY THE ENVIRONMENT IS GRATEFUL

The hemp and lime mixture enjoys a high standard of environmental sustainability. Hemp has a very fast life cycle, it's an extremely resistant plant, needs little water, grows without fertilisers, pesticides and herbicides. Furthermore, it enhances the soil by assimilating pollutants and has a great ability to absorb carbon dioxide by releasing oxygen. In fact, the hemp plant absorbs **4 times more CO² than other plants**. Lime is a natural material obtained by crushing limestone, a mineral that is found abundantly throughout the Italian territory.



DURABILITY BUILDINGS UNTOUCHED BY TIME

Lime and hemp constructions are not subject to oxidation by external agents, are frost-resistant and have an almost unlimited lifespan. The Ellora Caves, built in India in 600 AD, are the best example of the preservative properties of hemp which, mixed with lime, has protected and preserved the precious paintings of this archaeological site, now a UNESCO World Heritage Site, for hundreds of years.



MECHANICAL RESISTANCE LA LEGGEREZZA È LA FORZA

Buildings made of hemp fibre materials are **very resistant to dynamic stresses** because they are able to absorb vibrations. They are definitely suitable for use in seismic areas.



RECYCLING ENDLESS LIFETIME

At the end of its lifetime, the biocomposite of hemp and lime is **totally biodegradable** and reusable in accordance with the current practices of environmental protection, sustainability and energy saving.



CARBON NEGATIVE THE FIRST REGENERATIVE MATERIAL WITH A NEGATIVE CARBON FOOTPRINT

A recent Life Cycle Assessment study by the Politecnico di Milano, verified by ICMQ, led to the publication of an Environmental Product Declaration (EPD) which shows that Biomattone® and Bio Beton® contribute to removing between 44 and 105 kg of CO₂ from the atmosphere for every cubic metre of product, trapping it in the building envelope. This benefit stems from the speed at which the hemp plant grows, fixing atmospheric CO₂ carbon in its wood. The use of hemp shives in the production cycle allows for the overcompensation of all CO₂ emissions resulting from the entire life cycle of the products, making them "carbon negative" and therefore regenerative.



THE HOUSE THAT BREATHES



LIVING COMFORT CONSTANT LEVELS OF TEMPERATURE AND HUMIDITY



Thanks to the hygroscopic capacity of hemp and the vapour permeability of lime, the biocomposite is able to absorb and **regulate the level of humidity** inside the buildings. This prevents the formation of dew points, the proliferation of microorganisms, condensation, mould and the internal deterioration of the material. The purified air provides a pleasant and healthy living atmosphere. It also has good soundproofing characteristics which improve the acoustics inside the rooms.



THERMAL INSULATION OVER THE STANDARD

Hemp is an excellent natural insulator which is able to control sudden changes of temperature. It has an **excellent insulation capability** during winter and protects from heat in summer. The biocomposite cancels thermal bridges and increases the airtightness of the building.



FIREPROOF AND PROTECTION



FROM INFESTATIONS

Once mineralised by lime, the hemp shiv becomes fireproof and protects the walls from insects and rodents. Lime has always been used to **maintain hygiene and avoid infestations**.



ENERGY SAVING

FOR NEW AND EXISTING BUILDINGS

The remarkable thermal insulation performance reduces the needs for energy. A building built with hemp-and-lime blocks guarantees **energy savings that can reach up to 90-100%** if compared to another one that was built with traditional systems.



ECO-FRIENDLY AESTHETICS

The versatility of the biocomposites of hemp and lime allows you to customise each intervention and satisfy the insulation objectives **without compromising the aesthetic aspects thanks to hemp-based renders that are pleasing to the eye and to the touch..**



NEW CONSTRUCTION

Solutions designed for the construction of buildings with load-bearing structures of any types: reinforced concrete, wood and steel. Reactive mix materials that improve thermal, acoustic and hygrometric performance. Healthiness and environmental sustainability for your living space.



PERIMETER WALLS AND PARTITIONS

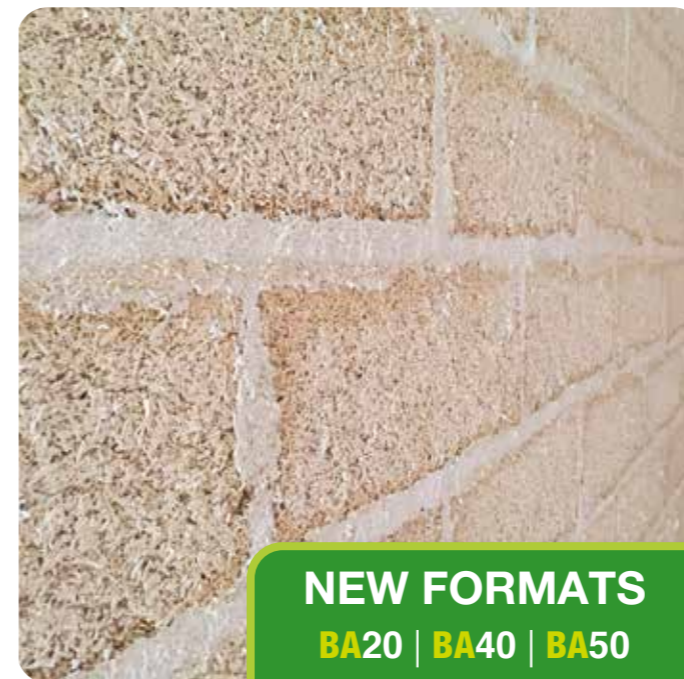

NEW FORMATS
BA20 | BA40 | BA50
 HIGHER LAYING PERFORMANCE
 LOWER INCIDENCE OF TRANSPORT

BIOMATTONE®

Biomattone® is a unique material that combines properties of insulation and thermal mass. It is composed of **Canapulo Grosso** (hemp shiv 0-25 certified CenC), **Legante Dolomitico Naturale** (hydrated dolomitic lime) and **Additivo Probiotico** (probiotics). It has all the characteristics required of a building material in line with sustainable development: high insulation capacity, low embodied energy and the ability to absorb CO₂ from the atmosphere. It can be used for the building envelope, ensuring its efficiency, or as an internal partition, contributing to the hygrothermal balance and therefore to the comfort of the living space.

FEATURES



APPLICATIONS



ASSEMBLY

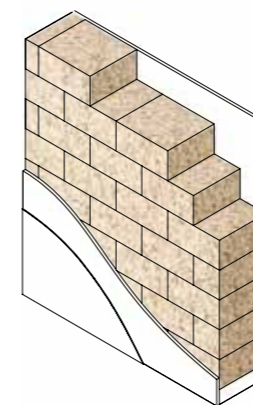

MALTA E CANAPA

Malta e Canapa is a premixed powder mortar composed of **Canapulo Fine 0-6mm**, limestone aggregates and special hydraulic and air-setting binders. It is designed for the construction of **Biomattone®** walls with excellent workability and consistent colour uniformity. It is classified as **Class M5** according to EN 998-2 for its compressive strength.

MALTA PRONTA

Malta Pronta is a highly breathable natural masonry mortar composed of **Canapulo Grosso** and **Legante Dolomitico Naturale**. The absence of hydraulic binders and mineral aggregates and the high cellulose content make it the ideal solution for laying **Biomattone®** masonry. It eliminates thermal bridges at the joints and allows for the creation of monolithic masonry made of hemp and lime.

NEW



ROOFS AND SUBFLOORS



BIO BETON®

Bio Beton® is a low-density biocomposite of hemp and lime that combines properties of insulation and thermal mass. It is composed of **Canapulo Grosso** (hemp shiv 0-25 certified CenC), **Legante Dolomitico Naturale** (hydrated dolomitic lime) e **Additivo Probiotico** (Probiotic additives). Ideal for the insulation of floors or slabs, roofs, attics, subfloors and cavity walls. The product is available in two solutions: premixed and ready to use, or bulk to be mixed on site.

FEATURES

Thermal insulation	Energy saving	Humidity regulator	Sound-absorbing
Living comfort	Fire resistant	Frost resistant	No insects or mould
Long-lasting	Eco-friendly	Carbon negative	Recyclable

APPLICATIONS



ASSEMBLY

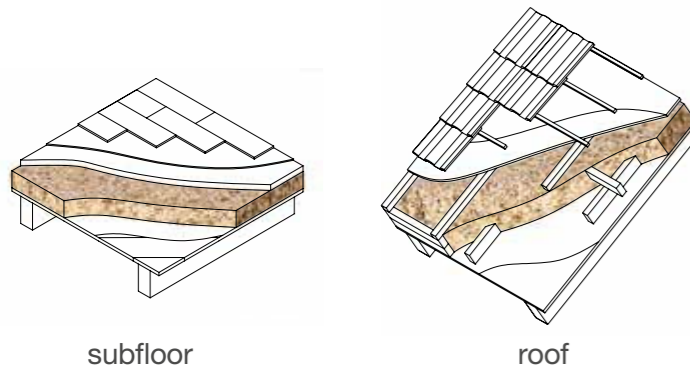

BIO BETON® PRONTO



BIO BETON® TO BE MIXED



ATTICS, DROPPED CEILINGS, AND ROOFS



CANAFIBER

Canafiber is the natural alternative to insulating materials from mineral and synthetic origin. It is compatible with any type of structure and it is the ideal product for thermo-acoustic insulation of roofs, walls and floor slabs for both new buildings and renovations.

The unique qualities of **Canafiber** are enhanced when used in combination with breathable materials such as **Biomattone®** of hemp and lime.

FEATURES

Thermal insulation	Energy saving	Sound-absorbing	Living comfort
Frost resistant	No insects or mould	Long-lasting	Eco-friendly

APPLICATIONS



ASSEMBLY

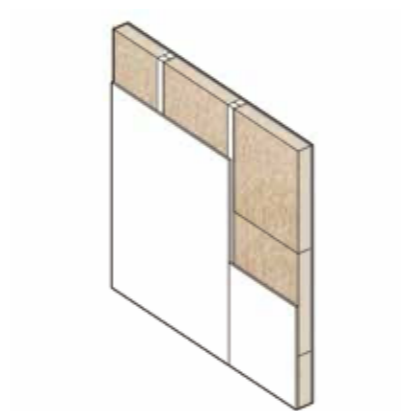

FLOOR SLABS



BIO SOLAIO®

Bio Solaio® is the innovative application of **Biomattonne®** in hemp and lime as an alternative to common brick and concrete floors. Creating **Bio Solaio®** in hemp and lime is fast, competitive and effective. The installation of the hemp and lime block with subsequent reinforcement and concrete casting allows for the creation of a lightweight structural floor that is both thermally and acoustically insulating. **Bio Solaio®** allows the envelope of new buildings to be completed in such a way as to obtain 360° natural protection with all the benefits of hemp and lime biocomposites in terms of energy efficiency, living comfort and health.

FEATURES

-  Thermal insulation
-  Energy saving
-  Humidity regulator
-  Sound-absorbing
-  Living comfort
-  Fire resistant
-  Frost resistant
-  No insects or mould
-  Long-lasting
-  Eco-friendly
-  Carbon negative
-  Recyclable

APPLICATIONS



ASSEMBLY

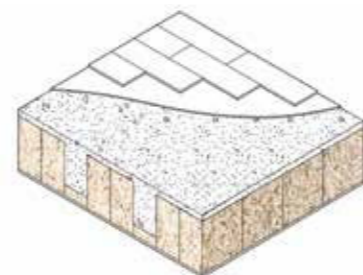

MO.HE BOUTIQUE HOTEL - LIVIGNO (SO)





ENERGY EFFICIENCY AND RENOVATION

Solutions that are compatible with all types of load-bearing structures: reinforced concrete, wood or steel. Bio-materials that ensure high performing features in terms of thermal, acoustic and hygrometric regulation. Wellness and environmental sustainability for your living space.



COUNTER WALLS



ATTICS



ROOFS



DROPPED CEILINGS



SUBFLOORS



THERMAL RENDERS



COUNTER WALLS



BIOMATTONE®

Il **Biomattone®** is used as an internal or external insulating wall, aiming to upgrade the energy efficiency of the building. The insulating counter wall is anchored to the existing support by doweling or nailing L-shaped brackets.



ASSEMBLY

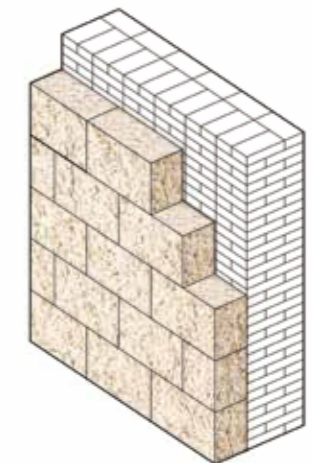

BIOMATTONE® + BIO BETON®

The creation of a cavity filled with granular material, such as **Bio Beton®**, is particularly suitable in cases where the existing support presents geometric irregularities. The final surface is uniform and the cavity is insulated homogeneously.

ASSEMBLY

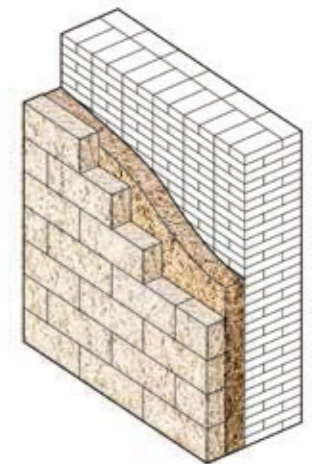

COUNTER WALLS



BIOMATTONE® + CANAFIBER

The combination of a counter wall of **Biomattone®** with an insulating cavity of hemp fibre panels, allows to reduce the thickness of the counter wall, without compromising the insulating capacity.

ASSEMBLY



GYPNUM FIBREBOARD/DRYWALL PANEL + CANAFIBER OR BIO BETON®

The formation of an insulating cavity wall using hemp fibre panels and gypsum fibreboards, is perfect for indoor environments that need to be insulated thermally and acoustically. This solution offers the possibility to reduce thicknesses and contributes to the breathability of the building envelope.

ASSEMBLY



ROOFS AND SUBFLOORS



BIO BETON®

Bio Beton® is a low-density biocomposite of hemp and lime that combines properties of insulation and thermal mass. It is composed of **Canapulo Grosso** (hemp shiv 0-25 certified CenC), **Legante Dolomitico Naturale** (hydrated dolomitic lime) and **Additivo Probiotico** (Probiotic additives). Ideal for the insulation of floor slabs, roofs, attics, subfloors and cavity walls. The product is available in in two solutions: premixed and ready to use, or bulk to be mixed on site.

FEATURES



APPLICATIONS



ASSEMBLY

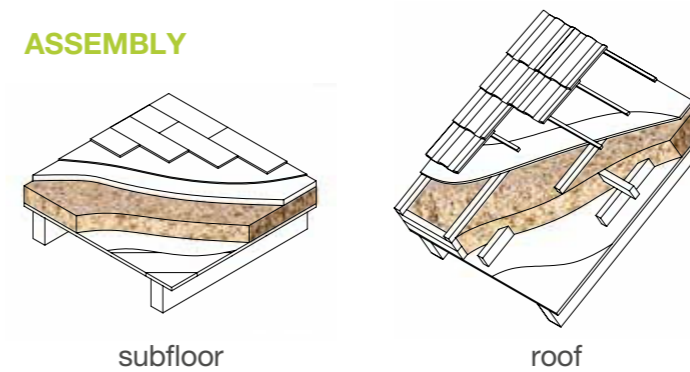

BIO BETON® PRONTO

BIO BETON® TO BE MIXED



ATTICS, DROPPED CEILINGS, AND ROOFS



CANAFIBER

Canafiber is the natural alternative to insulating materials from mineral and synthetic origin. It is compatible with any type of structure and it is the ideal product for thermo-acoustic insulation of roofs, walls and floor slabs for both new buildings and renovations.

The unique qualities of Canafiber are enhanced when used in combination with breathable materials such as **Biomattone**® of hemp and lime.

FEATURES



APPLICATIONS



ASSEMBLY

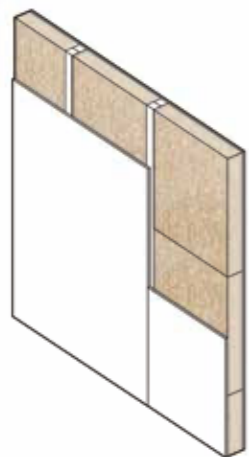

COATS



CANAFIBER CAPPOTTO

Canafiber Cappotto is a solid, eco-friendly insulation panel made from industrial hemp fibres. It has a high density and can be adapted to different structural shapes. It is mainly used as a thermal and acoustic insulation system for external walls. Its advantages include high breathability and excellent thermal and acoustic insulation properties. Thanks to these characteristics, it can completely replace polystyrene, glass wool or rock wool insulation systems. **Canafiber Cappotto** is the ideal choice for green building solutions.

FEATURES



APPLICATIONS

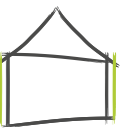

STRATIGRAFIA

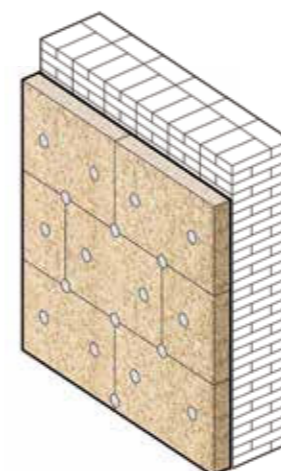



RENTERS AND FINISHES

Renders and finishes that are natural and highly breathable to ensure the healthiness of the building envelope and the living spaces. Hempcrete or mineral finishes in various colours for every tactile and visual preference.



THERMAL PLASTER



BIO BETON® 500 VENEZIA

Bio Beton® 500 Venezia is a highly breathable natural thermal plaster composed of **Canapulo Fine** (GenC-certified hemp wood), **Legante Dolomitico Naturale** (dolomite hydrated lime binder) and **Additivo Probiotico** (symbiotic microorganisms). The total absence of hydraulic binders and mineral aggregates, in addition to the high cellulose content, maximises the breathability of the masonry and makes **Bio Beton® 500 Venezia** the ideal solution for restoring masonry, even in the presence of rising damp and salt efflorescence.

FEATURES

- Thermal insulation
- Energy saving
- Humidity regulator
- Sound-absorbing
- Living comfort
- Fire resistant
- Frost resistant
- No insects or mould
- Long-lasting
- Eco-friendly
- Carbon negative
- Recyclable

APPLICAZIONI

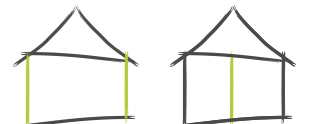

Ready-to-use product to be applied manually after removing the existing damaged plaster. **Bio Beton® 500 Venezia** can be left unfinished with a rustic and irregular effect or smoothed with **Canaposo** or **Canapulino** (textured finish) or with **Stabilitura Naturale Traspirante Plus** (civil finish) reinforced over the entire surface. Smoothed, sponged or rough finish with a reverse trowel.



PLASTER CYCLE WITH TEXTURED FINISHES



INTONACO E CANAPA

MINERAL PLASTER INTERIOR / EXTERIOR

Intonaco e Canapa is a premixed plaster based on natural hydraulic lime NHL 5 and **Canapulo Fine 0-6 mm**, with selected siliceous and calcareous aggregates. Breathable and natural, it regulates humidity and promotes healthy environments. Ideal for new and existing walls, it guarantees living comfort and durability, in full compliance with the principles of green building.



CANAPULINO®

INTERIOR/EXTERIOR MATERIAL FINISH

Canapulino® is a finish made from 18-month aged lime putty and **Canapulo Fine 0-6 mm** with the addition of calcium carbonates (natural colour) or crushed pottery powder or coloured earths (colour of your choice). Desalinating and dehumidifying thanks to its high hygroscopic capacity, it is an excellent humidity regulator on new and existing walls, ensuring maximum healthiness and significantly improving the living comfort of rooms.



CANAPOSÒ®

INTERIOR MATERIAL FINISH

Canaposo® is a finish made from 18-month aged lime putty and **0-1 mm Polvere di Canapa** powder with added calcium carbonate (natural colour) or Cocciopesto powder or coloured earth (colour of your choice). Desalinating and dehumidifying thanks to its high hygroscopic capacity, it is an excellent humidity regulator on new and existing walls, ensuring maximum healthiness and significantly improving the living comfort of rooms.

PLASTER CYCLE WITH TEXTURED FINISHES



EXTERNAL CYCLE



INTONACO DI CALCE NATURALE

Intonaco di Calce Naturale is a base coat plaster made from natural hydraulic lime NHL 5, designed to protect **Biomattone®** masonry. It is a specific formula with high water vapour permeability, particularly suitable for use on buildings of historical and artistic interest or for eco-friendly green building projects.

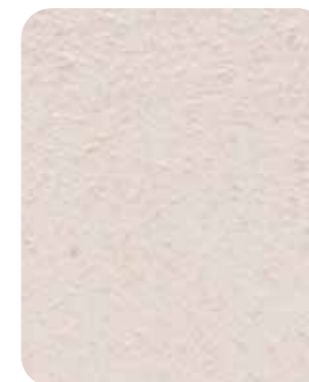

STABILITURA NATURALE TRASPIRANTE PLUS

Stabilitura Naturale Traspirante Plus is a mineral coating based on natural hydraulic lime, designed to protect **Biomattone®** masonry. Specifically formulated with high permeability to water vapour diffusion, it is particularly suitable for use on buildings of historical and artistic interest or for eco-friendly green building projects.

CICLO INTERNO



INTONACO DI CALCE NATURALE

Intonaco di Calce Naturale is a base coat plaster made from natural hydraulic lime NHL 5, designed to protect **Biomattone®** masonry. It is a specific formula with high water vapour permeability, particularly suitable for use on buildings of historical and artistic interest or for eco-friendly green building projects.



MALTA FINE

Malta Fine is a ready-to-use finishing plaster based on lime putty and graded sand. It is used in civil applications on base coats such as **Intonaco di Calce Naturale** or **Bio Beton® 500 Venezia**. For indoor use only.



PRODUCT DATA SHEETS



INSULATING MATERIAL



DESCRIPTION

Biomattone® is a masonry block that combines insulation and thermal mass properties. It is composed of hemp shiv (certified CenC), hydrated dolomitic lime and probiotics. Respecting the principles of social and environmental sustainability, it has all the characteristics required of a building material in line with sustainable development: high insulating capacity, low embodied energy and the ability to absorb CO2 from the atmosphere.

CHARACTERISTICS

- Thermal, acoustic and hygrometric comfort;
- **Biomattone®** is breathable (vapour permeable)
- Resistant to fire, frost, insects and rodents;
- Low energy consumption during manufacturing;
- Recyclable

APPLICATIONS

- Construction of insulating and breathable masonry walls;
- External wall insulation system for existing buildings;
- Internal wall insulation system for existing buildings;
- Solid floor insulation;
- Internal partitions with acoustic insulation.

LAYING

- The blocks are laid in a thin bed of mortar composed of hemp and lime according to the proportions indicated in the installation manual.
- A handsaw, reciprocating saw or alligator saw can be used to cut the blocks.
- Internal surfaces and partition walls can be coated with sand and lime mortar, clay, gypsum or other breathable finishes.
- External surfaces can be left exposed or can be coated with breathable finishes.

NB. [height] +/- 1 cm	BA8	BA12	NEW BA20	BA25	BA30	BA36	NEW BA40	NEW BA50
Sizes - Length, Height, Thickness - cm	50x20x8	50x20x12	50x40x20	50x20x25	50x20x30	40x20x36	50x20x40	40x20x50
Density - Kg/m³ dry	310	310	310	310	310	310	310	310
Conductivity - W/mk LAMBDA λ	0,044	0,044	0,044	0,044	0,044	0,044	0,044	0,044
Transmittance - W/m²K U	0,5	0,34	0,21	0,17	0,14	0,12	0,11	0,09
Total thermal resistance (Rt) - m²K/W	1,99	2,9	4,71	5,85	6,99	8,35	9,01	11,53
Thermal offset without plaster	3h 00'	5h 44'	11h 19'	14h 46'	18h 14'	22h 23'	25h 08'	32h 04'
Specific heat capacity - J/KgK	1280	1280	1280	1280	1280	1280	1280	1280
Vapour permeability - μ	4,5	4,5	4,5	4,5	4,5	4,5	4,5	4,5
Sound absorption coefficient (αw)	1 - CLASS A	1 - CLASS A	1 - CLASS A	1 - CLASS A	1 - CLASS A	1 - CLASS A	1 - CLASS A	1 - CLASS A
Soundproofing index (Rw) - dB					40	42	43	45
Compressive strength - N/mm2	0,4	0,4	0,4	0,4	0,4	0,4	0,4	0,4
Shear traction with rawplug - kN	2,067	2,067	2,067	2,067	2,067	2,067	2,067	2,067
Orthogonal traction with rawplug - kN	2,734	2,734	2,734	2,734	2,734	2,734	2,734	2,734
Reaction to fire with plaster	B - s1, d0	B - s1, d0	B - s1, d0	B - s1, d0	B - s1, d0	B - s1, d0	B - s1, d0	B - s1, d0
Fire resistance without plaster - min		EI60			EI180	EI180	EI180	EI180



INSULATING MATERIALS



AVAILABLE IN **25 KG** bags on disposable pallets weighing 1575 kg (63 bags) protected by an elastic hood

DESCRIPTION

Malta e Canapa is a premixed powder mortar with 0-6mm fine hemp shives designed for the construction of walls in **Biomattone®** hemp and lime, with excellent workability, consistent colour uniformity and limited possibility of salt efflorescence thanks to its water-repellent properties. The product can be used for raising and sealing external and internal walls built with **Biomattone®** hemp and lime bricks. The mortar is classified as Class M5 according to EN 998-2 for its compressive strength.

MIXING AND INSTALLATION

The **Biomattone®** to be laid must be clean and free of dust, soil, traces of oil or grease. In hot weather, the blocks must be slightly moistened with clean water before laying. **Malta e Canapa** is mixed with water in traditional construction site concrete mixers or continuous mixing machines, mixing approximately 5.0-6.0 litres of water per 25 kg bag of powder. It is advisable to maintain a constant water ratio until the end of the work. The mixture obtained in this way can be used within 2 hours. Stir again with a trowel before use without adding further water. To lay **Biomattone®**, after positioning the alignments and plumb lines, use a trowel to apply a consistent amount of product depending on the size of the product used. Remove any excess mortar and, once the plastic phase is complete, go over the joints with a special iron, making sure to keep the masonry clean during elevation.

COMPLIANCE

Factory-produced masonry mortar with guaranteed performance for general purposes (G) for use in walls, columns and partitions subject to structural requirements - EN 998-2:2016

COMPOSITION

Malta e Canapa is a powder formulation composed of special hydraulic and air-entraining binders, limestone aggregates, fine hemp shives (0-6 mm), inorganic pigments, mass water repellents and specific additives to improve the adhesion and workability of the product.

PRODUCT DATA

• Appearance:	powder
• Colour:	grey
• Powder density (EN 1015-10):	~ 1500 kg/m ³
• Maximum aggregate diameter:	≤ 2.0 mm

TECHNICAL DATA

• Density of fresh mortar (EN 1015-6):	~ 1800 kg/m ³
• Density of hardened mortar (EN 1015-10):	~ 1550 kg/m ³
• Adhesion (EN 1015-12):	≥ 0.15 N/mm ² (FP) B
• Air content of the mixture (EN 1015-7):	13%
• Consistency of fresh mortar (EN 1015-3):	150 mm
• Chloride content (EN 1015-17):	< 0.011%
• Compressive strength (EN 1015-11):	≥ 5.0 N/mm ² Class M5
• Flexural strength (EN 1015-11):	≥ 2 N/mm ²
• Capillary water absorption (EN 1015-18):	≤ 0.4 kg/m ² x min ^{0.5}

YIELD/CONSUMPTION

Dimension Biomattone®	Joint thickness	Approximate consumption
50x20x8	up to 15 mm	12,5 kg/m ²
50x20x12	up to 15 mm	12,5 kg/m ²
50x20x25	up to 15 mm	25 kg/m ²
50x20x30	up to 15 mm	25 kg/m ²
40x20x36	up to 15 mm	25 kg/m ²
50x20x40	up to 15 mm	25 kg/m ²
40x20x50	up to 15 mm	25 kg/m ²

CLEANING OF EQUIPMENT

Clean all tools and equipment with water immediately after use. Hardened material can only be removed by mechanical means.

EXPIRY/STORAGE

12 months from the date of manufacture. Store the product in its original packaging, intact and protected from moisture and frost.

APPLICATION DATA

• Mixing water:	20-24%
• Mixing ratio:	1 bag + 5-6 lt. of water
• Minimum application temperature:	+5°C
• Maximum application temperature:	+ 30°C
• Workability time:	≤ 120 minutes

• Water vapour permeability coefficient (EN 1015-19):	μ 15/35
• Thermal conductivity (EN 1745, A12):	0.61 W/mK
(average value from prospectus; P=50%)	
• Specific heat capacity (EN 1745,A12):	1,0 kJ/kgK
• Reaction to fire (EN 13501-1):	Class A1
(assessment based on provisions)	
• Durability (EN 998-1):	valid at the intended place of use of the mortar
• Hazardous substances (EN 998-1):	see SDS

WARNINGS

Avoid application at temperatures below +5°C, in strong wind, rain or direct sunlight. In high temperatures, it is advisable to wet the substrate with water before applying the mortar. Do not apply Biomattone® when frozen, during thawing or if there is a risk of frost in the 24 hours following installation. Apply mortar to a thickness of no less than 10 mm. Protect elevated surfaces from rapid drying due to strong winds and direct sunlight. Protect elevated surfaces from rain and frost for the first two days after installation. Product for professional use.

ENVIRONMENT, HEALTH AND SAFETY (REACH)

For further information and advice on the safe handling, storage and disposal of the material, users of the product should consult the latest version of the Safety Data Sheet (SDS) available, which contains information on the physical, ecological and toxicological characteristics of the products, together with other safety information. Product complies with the requirements of Regulation (EC) No. 1907/2006 (REACH) and Annex XVII, entry 47 and subsequent amendments and additions.

INSULATING MATERIAL



AVAILABLE IN BUCKETS OF **20L**

DESCRIPTION

Malta Pronta is a natural and highly breathable masonry mortar composed solely of Canapulo Grosso, Legante Dolomitico Naturale and symbiotic microorganisms. The total absence of hydraulic binders and mineral aggregates as well as the high cellulose component maximise the breathability of the masonry and make Malta Pronta the ideal solution for laying hemp-and-lime **Biomattone®** masonry walls. Highly energy-efficient, it eliminates the thermal bridges within the masonry, guarantees maximum healthiness and this results in a monolithic masonry from hemp and lime.

USE AND APPLICATION

Ready-to-use product to be applied manually. Spread the mortar in the center of the **Biomattone®** for at least 2/3 of the surface with a thickness of about 1 cm, necessary to regularise the surface for the next course of masonry. Before proceeding with the application of Malta Pronta, the **Biomattone®** must be moistened by spraying clean water.. Once the wall is finished, the mortar joints between the bricks can be filled and tooled. Tooling the joints allows to completely eliminate the thermal bridges generated by the Malta Pronta and offers a perfect uniformity of material on which the plaster will be applied. It is possible to proceed with the realisation of the cladding for a height up to about 3m without any problem. For higher heights and low thicknesses of the **Biomattone®**, it is advisable to proceed with the laying of about 1.5-2m in height, wait for the Malta Pronta to "set" and then continue.

Density - Kg/m ³ dry	500
Thermal Conductivity - W/mK	0,12
Vapour permeability - μ	2,7
Specific heat capacity - J/kgK	1330
Bending strength - N/mm ²	0,8
Compressive strength - N/mm ²	1,4
Adhesive strength to the substrate - N/mm ²	0,02

NOTE

The TecnoCanapa technical office is available for any support before, during and after the construction phase.



INSULATING MATERIAL



AVAILABLE IN BIG BAG 1 O 2 M³

DESCRIPTION

Bio Beton® is a massive insulating material that combines properties of insulation and thermal mass. It is composed of **Canapulo Grosso** (certified CenC), **Legante Dolomitico Naturale** (hydrated dolomitic lime) and **Additivo Probiotico** (symbiotic microorganisms). Respecting the principles of social and environmental sustainability, it has all the characteristics required of a building material in line with sustainable development: high insulating capacity, low embodied energy and the ability to absorb CO₂ from the atmosphere.

CHARACTERISTICS

- Thermal, acoustic and hygrometric comfort, Bio Beton® is breathable (vapour permeable).
- Resistant to fire, frost, insects and rodents.
- Absence of toxic fumes in case of fire.
- Low energy consumption during manufacturing.
- Recyclable.

APPLICATIONS

- Insulation of roofs, floors and attics.
- Construction of insulating and breathable masonry walls.
- External wall insulation system for existing buildings.
- Internal wall insulation system for existing buildings.
- Subfloor insulation.

LAYING

- The product is laid by casting it onto roofs, floor screeds, attics, subfloor or into formwork.
- The product is delivered already mixed and ready for use in 2 cubic meter big bags.

Thickness - cm	10	15	20	25	30	35	40
Density - Kg/m ³ dry	175	175	175	175	175	175	175
Thermal Conductivity - W/mk LAMBDA λ	0,053	0,053	0,053	0,053	0,053	0,053	0,053
Thermal Transmittance - W/m ² K U	0,49	0,34	0,26	0,21	0,17	0,15	0,13
Vapour permeability - μ	4,5	4,5	4,5	4,5	4,5	4,5	4,5
Specific heat capacity - J/KgK	1480	1480	1480	1480	1480	1480	1480
Compression behaviour (strain at 10%) - kPa	71	71	71	71	71	71	71
Thermal offset (according to ISO 13786)	2h 30'	4h 56'	7h 32'	10h 05'	12h 38'	15h 11'	17h 43'
Soundproofing index when placed on a wooden floor (Rw) - dB			40				
Reaction to fire on roof	B _{roof} (t2)	B _{roof} (t2)	B _{roof} (t2)	B _{roof} (t2)	B _{roof} (t2)	B _{roof} (t2)	B _{roof} (t2)

INSULATING MATERIAL

NEW

CANAFIBER CAPPOTTO



DESCRIPTION

CANAFIBER CAPPOTTO is a solid, environmentally friendly insulation panel made from industrial hemp fibres. It has a high density and the ability to adapt to different structural shapes. It is mainly used as a thermal and acoustic insulation system for external walls. Its advantages include high breathability and excellent thermal and acoustic insulation properties. Thanks to these characteristics, it can completely replace polystyrene, glass wool or rock wool insulation systems. **CANAFIBER CAPPOTTO** is the ideal choice for green building solutions.

ADVANTAGES

- Natural, ecological insulation for green building solutions
- Excellent thermal insulation properties
- High breathability
- Safety and healthiness
- Ease of processing and quick installation
- Maximum adaptability to the shape of buildings

APPLICATIONS

- Thermal and acoustic insulation of external walls
- Thermal and acoustic insulation of flat and sloping roofs
- Ceiling insulation

PROPERTIES

Thickness - mm	40	60	80	100	120	140	160
Density - kg/m ³	100	100	100	100	100	100	100
Thermal Conductivity - W/mk LAMBDA λ	0,039	0,039	0,039	0,039	0,039	0,039	0,039
Thermal Transmittance - W/m ² K U	0,836	0,585	0,45	0,368	0,308	0,266	0,234
Specific heat - J/KgK	1700	1700	1700	1700	1700	1700	1700
Sound absorption (aw)	aw 1 - Class A	aw 1 - Classe A	aw 1 - Class A	aw 1 - Class A	aw 1 - Class A	aw 1 - Class A	aw 1 - Class A
Vapour permeability - μ	≤ 2,0	≤ 2,0	≤ 2,0	≤ 2,0	≤ 2,0	≤ 2,0	≤ 2,0
Reaction to fire - Euroclasse	C-s2,d0	C-s2,d0	C-s2,d0	C-s2,d0	C-s2,d0	C-s2,d0	C-s2,d0

PACKAGING, STORAGE AND TRANSPORT

- Panels are packed on pallets measuring 1.100 x 1.200 mm with a height of 2.200 mm
- Pallets and panels must be stored under cover in a dry place.
- Transport must be carried out in closed vehicles to prevent the panels from getting wet.

DIMENSIONS AND PACKAGING

thickness (mm)	length (mm)	width (mm)	panels / pallet	m ² / pallet	m ³ / pallet
40	1100	600	106	69,96	2,798
60	1100	600	72	47,52	2,851
80	1100	600	52	34,32	2,746
100	1100	600	42	27,72	2,772
120	1100	600	36	23,76	2,851
140	1100	600	30	19,80	2,770
160	1100	600	26	17,16	2,740



INSULATING MATERIAL

CANAFIBER INTERCAPEDINE



DESCRIPTION

CANAFIBER INTERCAPEDINE is a high-quality insulating material made from industrial hemp fibre (85%) and polyester fibre (≤15%). A natural and sustainable product with exceptional insulating properties. The unique characteristics of hemp fibre in terms of thermal insulation, humidity regulation and noise reduction contribute significantly to a healthy and sustainable living environment, ensuring natural comfort.

Thickness - mm		40	60	80	100	120
Density - kg/m ³		30	30	30	30	30
Thermal Conductivity - W/mK	LAMBDA λ	0,039	0,039	0,039	0,039	0,039
Thermal Transmittance - W/m ² K	U	0,836	0,585	0,45	0,366	0,308
Specific heat - J/KgK		1700	1700	1700	1700	1700
Sound absorption (α _w)		0,70 - Class C	0,70 - Class C	0,70 - Class C	0,70 - Class C	0,70 - Class C
Vapour permeability - μ		≤ 2,0	≤ 2,0	≤ 2,0	≤ 2,0	≤ 2,0
Reaction to fire - Euroclasse		C-s2,d0	C-s2,d0	C-s2,d0	C-s2,d0	C-s2,d0

USE AND APPLICATIONS

CANAFIBER INTERCAPEDINE is the ideal product for thermo-acoustic insulation of roofs, walls and floors for both new buildings and renovations. **CANAFIBER INTERCAPEDINE** is the natural alternative to insulating materials of mineral and synthetic origin. It is compatible with any type of structure, from traditional concrete systems to more innovative ones such as steel or wood. The unique qualities of **CANAFIBER INTERCAPEDINE** are enhanced when used in combination with breathable and vapour permeable solutions such as **Bio Beton®** and **Biomattone®** of hemp and lime.

Thickness (mm)	Size (mm)	Panels / package	m ² / package	m ³ / package	Package / Pallet	m ² / Pallet	m ³ / Pallet
40	1100x600	12	7,92	0,3168	10	79,2	3,168
60	1100x600	8	5,28	0,3168	10	52,8	3,168
80	1100x600	6	3,96	0,3168	10	39,6	3,168
100	1100x600	5	3,3	0,33	10	33	3,3
120	1100x600	4	2,64	0,3168	10	26,4	3,168

INDUSTRIAL HEMP FIBER

- Unique thermal phase shift thanks to the high capacity to accumulate energy
- Endless life cycle
- It absorbs up to 20% of its weight in water vapour and self-regulates extraction and release
- Free of protein substances and unappetising to insects and rodents
- Energy consumption reduced by 90% compared to alternative synthetic and mineral insulation products
- It sequesters CO₂ during growth and contributes to the fight against climate change
- An excellent example of a circular economy

The annual cycle of industrial hemp fiber makes it a renewable non-toxic resource of high quality. The insulating materials in hemp fiber enjoy very high durability. They represent the ideal solution to create healthy and comfortable living spaces with an environmental impact reduced to a minimum.

DID YOU KNOW THAT...

- One hectare of agricultural land planted with hemp produces 9 tons of biomass per year which means, four times the production of one hectare of forest
- One hectare of hemp fiber sequesters 15 tons of CO₂ every time it is harvested
- The cultivation of industrial hemp doesn't need pesticides and enriches the soil

WHY CANAFIBER?

CANAFIBER INTERCAPEDINE is able to absorb noise, regulate humidity, prevent the appearance of condensation and mould and reduce internal temperature fluctuations. The panels are simple and pleasant to use and totally free of dangerous substances that can cause irritation of the skin and respiratory tract.

BULK PRODUCTS TO BE MIXED

CANAPULO GROSSO 0-25

HEMP SHIV 0-25



AVAILABLE IN BAGS OF 20 KG

DESCRIPTION

Canapulo Grosso 0-25 is obtained by mechanical scutching of hemp bales and subsequent shredding of the stems. **Canapulo Grosso 0-25** is produced with hemp that is cultivated, processed and packaged from selected and certified seeds in accordance with European legislation on the content of Δ9-THC.

COMPOSITION

- 100% sourced from hemp stalks
- 97,5% organic matter, of which:
- 52% cellulose, 18% lignin, 9% hemicellulose

DENSITY

- About 100 kg/m³ ± 5%

HUMIDITY

- Less than 19% of the raw material, Systematic control on incoming raw material;
- About 13% on average on the finished product, based on over 1500 measurements per year.

DUST

The residual dust rate is controlled and is less than 2% after the dust removal process by suction and passing through a 0.25 mm sieve.

PHYSICAL PROPERTIES

- Absorbing power: 375% (NF V19-002)
- Calorific value: 3690 cal/g (EN 14918)
- Thermal conductivity: 0,048 W/m.K (EN 12667)

GRANULOMETRY

Particle size measurements are regularly carried out by screening in order to check the dimensional regularity of the hemp shiv.

GRANULOMETRIC BREAKDOWN

- Greater than 40 mm: less than 2%
- From 20 to 40 mm: 0-3%
- From 2.5 to 20 mm: 93-98%
- From 0 to 2.5 mm: less than 3%

CHEMICAL

- Water: from 9 to 14%
- Dry matter from 85 to 90% of which:
- Total organic matter: 97.5% on dry matter, of which:
 - Crude cellulose: 52%
 - Lignin: 18%
 - Hemicellulose: 9%
 - Minerals:
 - Calcium: 5 g/kg (dry)
 - Magnesium: 0,17 g/kg (dry)
 - Phosphorus: 0,18 g/kg (dry)
 - Potassium: 1,8 g/kg (dry)
 - Total nitrogen: from 0,3 to 1% (dry)
 - Total carbon: 49,2% (dry)
 - C/N: 160
- Ashes: 2%
- PH in suspension at 10%: 6.7



BULK PRODUCTS TO BE MIXED

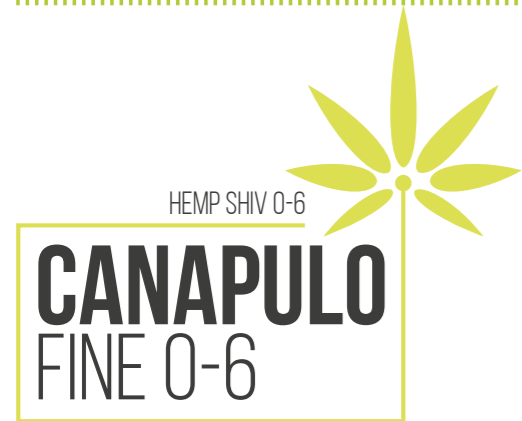

AVAILABLE IN BAGS OF 20 KG

DESCRIPTION

Canapulo Fine 0-6 is obtained by mechanical scutching of hemp bales and subsequent shredding of the stems. **Canapulo Fine 0-6** is produced with hemp that is cultivated, processed and packaged starting from selected and certified seeds in accordance with European legislation on the content of $\Delta 9$ -THC.

COMPOSITION

- 100% sourced from hemp stalks
- 97.5% organic matter, of which:
- 52% cellulose, 18% lignin, 9% hemicellulose

DENSITY

- About 130 Kg/m³ ± 5%

HUMIDITY

- 19% of the raw material, systematic control at the entrance;
- About 13% on average on the finished product, based on over 1500 measurements per year.

GRANULOMETRY

Particle size measurements are regularly carried out by screening in order to check the dimensional regularity of the hemp shiv.

Available in 20kg bags
(n.21 bags per pallet dim.80x120 h. 220cm)

GRANULOMETRIC BREAKDOWN:

- More than 4 mm: less than 3%
- 1- 4 mm: greater than 90%
- Less than 0.6 mm: less than 2%

CHEMICAL

- Water: from 9 to 14%
- Dry matter from 85 to 90% of which:
- Total organic matter: 97.5% on dry matter, of which:
 - Crude cellulose: 52%
 - Lignin: 18%
 - Hemicellulose: 9%
 - Minerals:
 - Calcium: 5 g/kg (dry)
 - Magnesium: 0,17 g/kg (dry)
 - Phosphorus: 0,18 g/kg (dry)
 - Potassium: 1,8 g/kg (dry)
 - Total nitrogen: from 0,3 to 1% (dry)
 - Total carbon: 49,2% (dry)
 - C/N: 160
- Ashes: 2%
- PH in suspension at 10%: 6.7

BULK PRODUCTS TO BE MIXED



AVAILABLE IN BAGS OF 20 KG

DESCRIPTION

Polvere di Canapa (Hemp powder) is obtained by mechanical separation. This process is done by crushing hemp bales which separates the internal part of the stem (hemp shiv) from the bark (hemp fibre). After a continuous process of grinding, dedusting and sieving, the product is reduced into fragments of the desired length.

USE

Polvere di Canapa (Hemp powder) is used as a natural inert component in lime-based finishes made with aged Lime Putty, Calcium Carbonates, Cocciopesto Powder or Colored Earth.

COMPOSITION

- Entirely sourced from cultivated hemp stalks that are transformed and packaged. Industrial hemp is cultivated starting from selected and certified seeds, in accordance with European legislation on $\Delta 9$ -THC content.

GRANULOMETRY

From 0 to 1 mm. Particle size measurements are regularly carried out by screening in order to check the dimensional regularity of the hemp shiv.

DENSITY

About 180 kg/m³

CHEMICAL

- Water: from 9 to 14%
- Hemicellulose: 34,60%
- Resistant Cellulose: 36,50%
- Holocellulose: 71,10%
- Lignin 20,40%
- Ashes: 1,60%
- Minerals:
 - Calcium: 0,89 - 1,40%
 - Magnesium: 0,06 - 0,02%
 - Phosphorus: 0,2 - 0,5%
 - Potassium: 0,96 - 1,5%
 - Total nitrogen: from 0,4 - 1%
 - Sodium: 0,09%
 - Sulfur: 0,10 - 0,16%

PACKAGE

Bags of 20kg



BULK PRODUCTS TO BE MIXED

NATURAL DOLOMITIC BINDER

LEGANTE DOLOMITICO NATURALE



AVAILABLE IN BAGS OF 25 KG

DESCRIPTION

Legante Dolomitico Naturale is a natural aerial binder without chemical or cement additives, designed for the on-site preparation of hemp biocomposites belonging to the **Bio Beton®** line by Senini, suitable for the restoration of historic buildings, renovations, new constructions and for the emerging needs of Neo-building to construct NZEBs (Nearly Zero Energy Buildings)

APPLICATIONS

Used in new constructions, renovations and architectural restoration as a binder for the production of hemp and lime biocomposites such as **Bio Beton®** (masonry infill, insulating walls, roof insulation, attic and subfloor systems), **Malta Pronta (Biomattone®)** masonry), and for base and finish coating systems.

USE

Legante Dolomitico Naturale is mixed with hemp shiv following specific ratios, thus creating ideal biocomposites for plasters, insulating walls, external insulation and substrates. **Legante Dolomitico Naturale** stabilises the hemp, which in turn, thanks to its silica component (about 5%), hydraulifies the high content of aerial lime. Mixing both elements protects the biocomposite from fire, decomposition, or attack by rodents and insects. The hemp enhances all the characteristics of natural lime by increasing its porosity, breathability, permeability to water vapour and ability to manage humidity in living spaces. Hemp shiv also adds workability and structural body, allowing to coat vertical walls with a single application of thermal plaster, for a thickness of 1 to 45 cm.

TECHNICAL DATA - 'LEGANTE DOLOMITICO NATURALE'			
Density	400-550 Kg/m ³	Residue of a 0.09 mm	≤ 7%
Physical state and colour	White dust	Residue of a 0.02 mm	≤ 2%
Humidity	< 2,5%	Content SO ₃	≤ 0,8%

PHYSICAL CHARACTERISTICS

- Physical state: solid in fine powder;
- White colour;
- Odor: none;

METHOD OF SUPPLY

- Loose in tanker with pneumatic unloading
- Packaged in 25 kg bags
- Storage must take place in a dry place. We recommend the use within 8 weeks.

WARNINGS

Do not apply in conditions of strong solar radiation or if exposed to the action of the wind. In any case, carry out the work at ambient temperatures between 5 ° C and 35 ° C. Protect from fast drying and frost. 'Legante Dolomitico Naturale' has a very high content of aerial lime, it is recommended to use personal protective equipment and, in case of contact with the eyes, consult a doctor immediately. Don't rub. Wash immediately abundantly and for a long time with drinking water (possibly sugared) or with specific eye washes. Go to the emergency room as soon as possible. If in contact with the skin, wash the affected area with plenty of water and soap. If inhaled, irrigate the nose and rinse the throat with drinking water. Product intended for professional use. Adequately protect the parts for which the product is not intended. The operator must be equipped with the provisions of current safety regulations. We decline all responsibility for damage that may result from improper use of the product. Unused material and packaging must be disposed of as waste.

NOTE

The company reserves the right to modify the above information over time, while maintaining the characteristics of the product

BULK PRODUCTS TO BE MIXED

PROBIOTIC ADDITIVE

ADDITIVO PROBIOTICO



AVAILABLE IN A JERRY CAN OF 20LT OR TANK OF 1000 LT

DESCRIPTION

Additivo Probiotico is a symbiotic blend of microorganisms found in nature that allow to reverse and regenerate oxidative and degenerative processes. Added to Thick or Thin Hemp Shiv, Natural Dolomitico Binder and Water, **Additivo Probiotico** allows to speed up the lime carbonation process, providing to the biocomposites, greater short-term mechanical resistance and shorter drying time. Furthermore, this composition allows to eliminate any mould problems in the slow drying phase of the biocomposites, as the probiotics present feed on the bacteria that give rise to moulds.

COMPOSITION

- Mineral salts
- Raw sugar cane molasses
- Water and microorganisms

PH VALUE

Between 3.4 and 3.7

STORAGE

In a dark place between 5 and 25 degrees centigrade.

SMELL

The smell must be slightly acidic, typical of fermented products.

INDICATIONS

No particular precautions in case of physical contact with parts of the body even if accidentally ingested.

USE

Mix **Additivo Probiotico** with thick or thin Hemp Shiv, Natural Dolomitico Binder and Water in the following quantities depending on the application:

Bio Beton®	2 l/m ³
Natural Beton® 200	2 l/m ³
Natural Beton® 300	4 l/m ³
Natural Beton® 500 Venezia	0,5 l/secchio

PRESENT MICROORGANISMS

Non-pathogenic symbiotic bacterial cultures including lactic acid bacteria, photosynthesis bacteria and yeasts.

WEIGHT

1.1 kg per liter of activated product.

COLOR

The product has a dark brown color slightly transparent against the light.

ENVIRONMENT

Completely biodegradable, it leaves no toxic or harmful residues for humans and the environment.



RENDERS AND FINISHES



AVAILABLE IN 20 KG BUCKETS - YIELD PER BUCKET: 1.5 SQM FOR 1 CM OF THICKNESS

DESCRIPTION

Bio Beton® 500 Venezia is a natural and highly breathable thermal plaster composed solely of **Canapulo Fine**, **Legante Dolomitico Naturale** and Symbiotic Microorganisms. The total absence of hydraulic binders and mineral aggregates in addition to the high cellulose component maximises the breathability of the masonry and makes **Bio Beton® 500 Venezia** the ideal solution for restoring masonry even in presence of rising damp and efflorescence of salts. With high energy efficiency, it is an excellent humidity regulator on new and existing walls, guarantees maximum healthiness and significantly improves the comfort of the living spaces.

APPLICATIONS

Ready-to-use product to be applied manually. Before application, remove the existing damaged plaster and make sure that the substrate is free of friable parts. Apply a first coat of **Bio Beton® 500 Venezia** as a rough coat on the masonry and then apply several coats to reach the desired thickness, smooth and trowel. **Bio Beton® 500 Venezia** can be finished by leaving the fine hemp shiv exposed (material finish) or coated with 'Natural Breathable setting coat' or a skim coat of lime and sand.

Thickness - cm	3	5
Density - Kg/m ³ dry	500	500
Thermal conductivity - W/mK	0,12	0,12
K Thermal Transmittance - W/m ² K	2,38	1,70
Vapour permeability - μ	4,5	4,5
Specific heat capacity - J/kgK	1330	1330
Bending strength - N/mm ²	0,8	0,8
Compressive strength - N/mm ²	1,4	1,4
Adhesive strength to the substrate - N/mm ²	0,02	0,02
Reaction to fire	B-s1-d0	B-s1-d0

NOTE

The TecnoCanapa technical office is available for any support before, during and after the construction phase.

PLASTERS AND FINISHES



AVAILABLE IN 25 KG on disposable pallet of 1575 kg (63 bags) protected by elastic hood

DESCRIPTION

Intonaco e Canapa is a special plaster based on natural hydraulic lime NHL 5 and Fine Hemp Shiv 0-6 mm, designed for breathable protection, renovation and conservative restoration of even heterogeneous masonry, such as hemp and lime **Biomattone®**, brick, tuff rock, natural stones. Specifically formulated with high permeability to water vapour, it is intended for filling, scratch coat, base plaster and rustic finishing of new or old masonry, both internal and external. Due to its natural properties and coloration, it is particularly suitable for works on buildings of historical and artistic interest, or for eco-friendly green building projects.

SUBSTRATE PREPARATION

Substrates to be plastered must be stable, clean, solid and free of weak parts, dust, bacterial growth, saline efflorescence, oils, greases, waxes, residues of previous works, etc. If necessary, carry out preliminary cleaning of the substrate by pressure washing or sandblasting. The product can be mixed manually with a low-speed electric mixer or applied by mechanical projection using plastering machines for pre-mixed products.

YIELD/CONSUMPTION

15 kg for m² for cm thickness..

PRODUCT DATA

- Appearance: powder
- Colour: hazelnut beige
- Bulk density of powder (EN 1015-10): ~ 1400 kg/m³
- Maximum aggregate size: ≤ 2 mm

APPLICATION DATA

- Mixing water: 24%
- Mixing ratio: 1 bag + 6 lt. of water
- Minimum application temperature: +8°C
- Maximum application temperature: + 35°C
- Workability time: ≤ 120 minutes

TECHNICAL DATA

- Bulk density of fresh mortar (EN 1015-6): ~ 1700 kg/m³
- Bulk density of hardened mortar (EN 1015-10): ~ 1400 kg/m³
- Adhesion (EN 1015-12): ≥ 0.2 N/mm² (FP) B
- Compressive strength (EN 1015-11): 1 N/mm² Class M5
- Flexural strength (EN 1015-11): ≥ 0.5 N/mm²
- Water absorption by capillarity (EN 1015-18): ≤ 0.4 kg/m² x min^{0.5}W1
- Water vapour permeability coefficient (EN 1015-19): μ 6
- Thermal conductivity (EN 1745): 0.45 W/mK (mean value from data table; P=50%) A12
- Specific heat capacity (EN 1745,A12): 1, kJ/kgK
- Reaction to fire (EN 13501-1): Class A1 (assessment based on provisions)
- Durability (EN 998-1): valid in the intended place of use of the plaster
- Hazardous substances (EN 998-1): see SDS

WARNINGS

Avoid application at temperatures below +5°C, in the presence of strong wind, rain or direct sunlight, or above +35°C. Temperatures below +8°C combined with high relative humidity may lead to surface carbonation. The colour appearance may vary depending on environmental application conditions. With high temperatures, it is recommended to wet the substrate with water before applying **Intonaco e Canapa**; it is advisable to wet the plaster for a few days after application in order to avoid cracking and excessive dehydration that could cause loss of mechanical strength of **Intonaco e Canapa**. Avoid application on frozen, dusty, unstable or inconsistent substrates. Apply layers of thickness between 10 and 20 mm per coat. Protect the applied product from frost, rain and rapid drying during the first 24 hours after application. **Intonaco e Canapa** is a naturally coloured product and therefore subject to colour variations due to changes in the extraction of marly limestone from which the natural hydraulic lime is obtained. For professional use only.

MIXING AND APPLICATION

For manual applications, mix **Intonaco e Canapa** by adding 6-6.5 litres of clean water per 25 kg bag in a concrete mixer. Add the correct quantity of water into the mixer, then add the product powder. Mix for about 2-3 minutes until obtaining a homogeneous, lump-free mortar. Apply the product with a trowel like a traditional plaster. The mixed product must be used within 2 hours from mixing with water. The preparation of corner beads, separation strips, level guides, etc., must be carried out before applying the plaster layer on the entire wall. For mechanical projection applications, apply the product evenly, in a single layer with a thickness between 10 and 20 mm. It is possible to apply successive layers provided that the previous one is not yet completely dry. Afterwards, the plaster is levelled and finished using an aluminium straightedge. Any burrs or excess material are removed by scraping and smoothing of the surfaces. The surfaces thus prepared are suitable to receive finishing products: to obtain a fine civil finish use **Malta Fine** indoors and **Stabilitura Naturale Traspirante Plus** outdoors; to obtain a textured finish use **Canapulino** or **Canaposo**.

COMPOSITION

Intonaco e Canapa is a pre-mixed mineral plaster based on natural hydraulic lime NHL 5, fine hemp shiv 0-6 mm, selected siliceous and calcareous aggregates dosed according to an appropriate granulometric curve, and specific additives that improve workability, breathability, and adhesion to substrates.

CAM

The product **Intonaco e Canapa** contains more than 20% recycled material by weight, certified according to UNI/PdR 88:2020 (**CAM - Minimum Environmental Criteria** pursuant to Decree 23 June 2022 No. 256).

TOOL CLEANING

Clean all tools and equipment with water immediately after use. Hardened material can be removed only by mechanical means.

SHELF LIFE/STORAGE

12 months from the date of manufacture. Store the product in its original, intact packaging and protected from moisture and frost.

ENVIRONMENT, HEALTH AND SAFETY (REACH)

For further information and advice on handling, storage and safe disposal of the material, the user must consult the latest version of the Safety Data Sheet (SDS), which reports information on the physical, ecological and toxicological characteristics of the products (REACH), together with other safety information. Product compliant with the provisions of Regulation (EC) No. 1907/2006 (REACH) and Annex XVII, entry 47 and subsequent amendments and additions.

COMPLIANCE

Guaranteed performance masonry mortar for general purposes (G) produced in a factory, intended for use in walls, columns, and partitions subject to structural requirements. - EN 998-2:2016



RENDERS AND FINISHES



AVAILABLE IN BUCKETS OF 20 KG - YIELD PER BUCKET: 3 M² FOR 5 MM THICKNESS

DESCRIPTION

Canapulino is a lime putty-based finish made with 18-month aged lime putty and fine hemp shiv (0–6 mm), with the addition of Calcium Carbonates (natural colour) or Cocciopesto Powder or Coloured Earth (colour of choice). The total absence of hydraulic binders and the high cellulose content maximise the breathability of the masonry, making **Canapulino** the ideal solution for the consolidation and completion of finishes, plasters and masonry. Desalinating and dehumidifying thanks to its high hygroscopic capacity, it is an excellent humidity regulator on new and existing walls, guarantees maximum indoor health and significantly improves the living comfort of indoor spaces.

APPLICATION

Ready-to-use product to be applied manually with a thickness of 5–10 mm. Before application, remove any damaged existing plaster and ensure that the substrate is free of friable parts. Apply a first coat of **Canapulino** as a rough coat on the masonry, then apply several coats until reaching the desired thickness, level and float.

Specific weight	1.110 kg/m ³
Vapour permeability - μ	4,5

NOTE

Tecnocanapa's technical office is available for any support before, during and after the implementation phase.

The company is constantly improving and updating its product range.

Technical data, packaging and packing are therefore necessarily subject to change without notification.

Customers can always check with the company: technical data, documentation and samples.

For optimal use of our products, it is recommended to faithfully follow the instructions given in the Technical User Manual that is provided with the material or upon request.

Edition & Copyright • 01/2022

RENDERS AND FINISHES



AVAILABLE IN BUCKETS OF 20 KG - YIELD PER BUCKET: 5 M² FOR 3 MM THICKNESS

DESCRIPTION

Canaposo is a lime putty-based finish made with 18 months aged lime putty and **Polvere di Canapa 0-1 mm** (hemp powder) with the addition of Calcium Carbonates (natural colour), Cocciopesto Powder or Coloured Earth (colour of choice). The total absence of hydraulic binders and the high cellulose content maximise the breathability of the masonry, making **Canaposo** the ideal solution for the consolidation and completion of finishes, plasters and masonry. Desalinating and dehumidifying thanks to its high hygroscopic capacity, it is an excellent humidity regulator on both new and existing walls, guarantees maximum indoor health and significantly improves the living comfort of indoor spaces.

APPLICATION

Ready-to-use product to be applied manually with a thickness of 2–3 mm. Before application, make sure that the substrate is linear and homogeneous. Apply a first coat of **Canaposo** on the masonry, then apply several coats until reaching the desired thickness, level and float.

Bulk density	1.110 kg/m ³
Water vapour diffusion resistance - μ	4,5

NOTE

The TecnoCanapa technical office is available for any support before, during and after the application phases.



RENDERS AND FINISHES



AVAILABLE IN BAGS OF 25 KG

DESCRIPTION

ICN - Intonaco di Calce Naturale is a special plaster based on natural hydraulic lime NHL 5, designed for the protection, recovery and breathable conservative restoration of masonry walls, including heterogeneous ones, in brick, tuff rock and natural stone. Its specific formulation ensures high water-vapour diffusion permeability, making it suitable for filling, scratch coats, base coats and rustic finishes on new or existing walls, both internal and external. Due to its properties and natural colouring, it is particularly recommended for works on buildings of historical and artistic interest, as well as for eco-friendly green building applications.

INSTALLATION

The substrates must be stable, clean, solid and free from weak parts, dust, biological growths, saline efflorescence, oils, greases, waxes and residues from previous work. If necessary, clean the substrate in advance by pressure-washing or sandblasting. The product can be mixed manually with a low-speed electric mixer or applied by mechanical projection using machines for premixed mortars. For manual applications, mix ICN by adding approximately 6.0-6.5 litres of clean water per 25-kg bag. Add the water first, then the powder, and mix for 2-3 minutes until a homogeneous, lump-free mixture is obtained. Apply the product manually with a trowel as a traditional plaster. Use the mixed product within 3 hours. Corner beads, division strips, level guides and similar elements must be installed before applying the plaster. For mechanical projection, apply the material in a single, even coat, with a thickness between 10 and 20 mm. Additional coats may be applied as long as the previous one is not completely dry. Afterwards, level and finish using an aluminium straightedge. Remove burrs or excess material by scraping and planing the surfaces. On heterogeneous substrates or in the presence of structural discontinuities, embed the ARMANET 10x10 alkali-resistant glass fibre mesh. The mesh must extend about 30 cm beyond the discontinuity line and must be placed within the plaster thickness, not directly against the masonry. The prepared surfaces are then suitable to receive finishing products.

COMPLIANCE

General purpose (GP) mortar for interior / exterior plasters - EN 998-1

COMPOSITION

Premixed mineral plaster based on natural hydraulic lime NHL 5, siliceous and calcareous aggregates selected and dosed in an appropriate granulometric curve and specific additives that improve its performance in terms of workability, breathability and adhesion to substrates.

TECHNICAL DATA

- Natural color: light hazel beige
- Density of the powder: ~ 1350 kg/m³ - EN 1015-10
- Maximum diameter of the aggregate: 2,0 mm
- Density of fresh mortar: ~ 1750 kg/m³ - EN 1015-6
- Density of the hardened mortar: ~ 1450 kg/m³ - EN 1015-10
- Adhesion: 0,15 N/mm² (FP) B - EN 1015-12
- Air content of the mix: 17% - EN 1015-7
- Compressive strength: 2,0 N/mm² CS II - EN 1015-11
- Flexural strength: 1,0 N/mm² - EN 1015-11
- Water absorption by capillarity: W0 - EN 1015-18

WARNINGS

Avoid application at temperatures below + 5 ° C, in the presence of strong winds or rain and under direct sunlight, or above + 35 ° C. Temperatures below + 8 ° C with a high percentage of relative humidity can give rise to superficial carbonation phenomena. The chromatic aspect may vary according to the environmental conditions of application. At high temperatures it is recommended to wet the substrate with water before applying the plaster; it is advisable to wet the plaster for a few days after laying in order to avoid cracking and high dehydration, which would decrease its mechanical resistance. Avoid application on frozen, dusty, unstable and inconsistent substrates. Apply coats with thicknesses between 10 and 20 mm. Protect the applied product from frost, rain and rapid drying for the first 24 hours after application. ICN - Intonaco di Calce Naturale is a product with natural colouring and is therefore susceptible to chromatic variations due to the progress of the extraction of the marly limestone.

NOTE

Product for professional use. The data and prescriptions reported in this sheet, based on the best practical and laboratory experiences, are to be considered indicative in any case. Considering the different conditions of use and the intervention of factors independent of Senini (type of substrate, environmental conditions, directions of technical installation, etc.), whoever intends to use it is therefore required to establish whether the product is suitable for use or not. Our guarantee obligation is therefore limited to the quality and constancy of the same in relation to the finished product, and exclusively for the above data. The Senini company reserves the right to make technical changes without prior notice. This technical data sheet cancels and replaces any previous edition.

RENDERS AND FINISHES



AVAILABLE IN BAGS OF 25 KG

DESCRIPTION

Stabilitura Naturale Traspirante Plus is a mineral coating based on natural hydraulic lime, designed for the protection, breathable conservative restoration and recovery of civil plasters and natural dehumidifying systems. Its specific formulation ensures high water-vapour diffusion permeability, making it suitable for obtaining natural surface finishes with a sponged or trowelled civil appearance. Due to its natural properties and colouring, it is particularly recommended for interventions on buildings of historical and artistic interest or for eco-friendly green building applications.

COMPOSITION

Premixed mineral product based on natural hydraulic lime, selected and properly graded calcareous aggregates and specific additives that improve its performance in terms of workability, breathability and adhesion to substrates.

MIXING

Mix a 25 kg bag of **Stabilitura Naturale Traspirante Plus** in approximately 7.0-8.0 liters of clean water and mix with a low-speed mixer drill until a homogeneous and lump-free mixture is obtained. Let the mixture rest for about 3 minutes and stir briefly before use. The mixture thus obtained can be used within 90 minutes of its mixing. The product can also be used advantageously by continuous plastering machines.

APPLICATION DATA

- Mixing water: 28-32%
- Mixing ratio: 1 bag + 7.0-8.0 litres of water
- Minimum application temperature: + 8 ° C
- Maximum application temperature: + 35 ° C
- Workability time: 90 minutes

PRODUCT DATA

- Appearance: powder
- Colour: Light hazel beige
- Density of the powder: ~ 1150 kg / m³ - EN 1015-10
- Maximum diameter of the aggregate: 1.0 mm
- Indicative consumption: 3.0-5.0 kg per m²
- Packaging: 25 kg bags on a pallet of 63 bags
- Conservation: 12 months in original intact packaging and sheltered from humidity

NOTE

Product for professional use. The data and prescriptions reported in this sheet, based on the best practical and laboratory experiences, are to be considered indicative in any case. Considering the different conditions of use and the intervention of factors independent of Senini (type of substrate, environmental conditions, directions of technical installation, etc.), whoever intends to use it is therefore required to establish whether the product is suitable for use or not. Our guarantee obligation is therefore limited to the quality and constancy of the same in relation to the finished product, and exclusively for the above data. The Senini company reserves the right to make technical changes without prior notice. This technical data sheet cancels and replaces any previous edition.

INSTALLATION

Stabilitura Naturale Traspirante Plus can be applied to any traditional mineral substrate and surface: traditional lime-based plasters, premixed plasters based on natural hydraulic lime, cement-lime mortars, restoration plasters, traditional, stable, consistent and non-crumbling traditional substrates. The substrates to be treated must be homogeneous, stable, clean, consistent, free from weak parts, dust, bacterial proliferation, saline efflorescence, oils, greases, waxes, residues from previous processing. If necessary, carry out a preliminary cleaning of the substrate by pressure washing or sandblasting. The surfaces must be dry and free or adequately protected from capillary rising damp phenomena.

WARNINGS

Avoid application at temperatures below +8°C, in the presence of strong winds or rain, under direct sunlight or above +30°C. Temperatures below +8°C with high relative humidity may cause surface carbonation. At high temperatures, wet the substrate evenly before applying the skim coat. Avoid application on frozen, dusty, unstable or inconsistent substrates. Apply skim coats with thicknesses between 2 and 8 mm per layer. Avoid direct application on substrates made of gypsum, fibre-cement or mineral/organic foam panels. The colour may vary depending on the environmental conditions during application. Coloured products must be applied on homogeneous substrates. Always use the same amount of water to avoid colour variations. On large surfaces, allow for interruptions near joints or downspouts, or create suitable technical cuts. Avoid resuming work with time gaps on the same wall. Protect the applied product from frost, rain and rapid drying for the first 24 hours. Stabilitura Naturale Traspirante is a naturally coloured product and is therefore subject to colour variations due to the extraction progress of the marly limestone from which natural hydraulic lime is obtained.



RENDERS AND FINISHES



AVAILABLE IN BAGS OF 25 KG

DESCRIPTION

Malta Fine is a ready-to-use finishing plaster made of lime putty and graded sands.

USE

Malta Fine is used as a finishing plaster for civil use on base plasters such as **Intonaco di Calce Naturale** or **Bio Beton® 500 Venezia**. For internal use only.

SURFACE PREPARATION

The surface to be coated must be flat, coplanar and free of dust and dirt. Any traces of oils, greases, waxes, etc. must be removed beforehand. **Malta Fine** can be applied on a dry base plaster after it has been previously moistened.

PROCESSING

Apply with a metal trowel for a thickness of maximum 3 mm. After application, moisten and finish with a fine sponge float. It does not require mesh reinforcement.

STORAGE

If protected from frost, it has an unlimited duration.

TECHNICAL DATA

Specific weight - Kg/m ³ dry	ca. 1.700 kg/m ³
Granulometry	< 0,6 mm
Yield	ca. 3-4 kg/m ²
Maximum thickness of application	ca. 3 mm
Vapour permeability - EN 1015-19	$\mu \leq 9$ (measured value)
Water absorption by capillarity - EN 1015-18	W0
Thermal conductivity - EN 1745	$\lambda = 0,45$ W/m·K (table value)
Class - UNI EN 998-1	GP-CSI-W0

SOME OF OUR REALISATIONS

LIVIGNO (SO)



LONDRA - REGNO UNITO



PORTO RECANATI (MC)





CANEVA (PN)



UNIVERSITÀ DI PISA



SAN CATALDO (LE)



MALUA BAY - AUSTRALIA



OSAKA - GIAPPONE



ESLÖV - SVEZIA



Lavoriamo per il benessere dell'Uomo e dell'Ambiente®

SENINI - Via Erculiani 192 - 25018 Novagli di Montichiari - BS

Company Number: 030 9665711

Toll-free Number: 800 172 553 - tecnocanapa@senini.it

www.tecnocanapa-bioedilizia.it

MADE IN THE BEAUTIFUL ITALY