



TECNO
CANAPA
NATURAL BUILDING

CONSTRUCTION
SOLUTIONS



NATURAL SOLUTIONS WINNING SOLUTIONS

In response to your kind request for information, we are here to show you the different opportunities and building solutions that we propose for green building projects with **Bio Beton®**, biocomposite of hemp and lime, together with the most innovative construction systems.

A set of solutions aimed at achieving a high-quality building standard while satisfying the requirements of comfort, naturalness, and healthiness.

Following the acquisition of the patent and the branch **Equilibrium** (more than 500 building sites across Italy including a NZEB building of 20 apartments, winner of the Green Building Solutions Awards 2016), with the product range **TecnoCanapa** we are now able to offer better technical solutions that are also more competitive economically speaking. They really guarantee high standards of comfort and thermal insulation for buildings. Healthiness, energy saving and quality of life are the elements that distinguish our interventions in natural building.



PREMIO
ALL'INNOVAZIONE
AMICA
DELL'AMBIENTE



The building envelope:

The walls and the roof built with **Bio Beton®** and **Blocco Ambiente®** of hemp and lime.

Hereunder are different possible solutions for the building envelope built with the patented biocomposites **Bio Beton®** and **Blocco Ambiente®**, both composed of hemp shiv, dolomitic lime, and probiotics, without any hydraulic or chemical additive. Every solution makes the building completely natural and breathable.

The durability is also increased because over time, the dolomitic lime improves the mechanical characteristics of the building. In fact, dolomitic air lime doesn't fear aging unlike any other mortar or hydraulic binder.

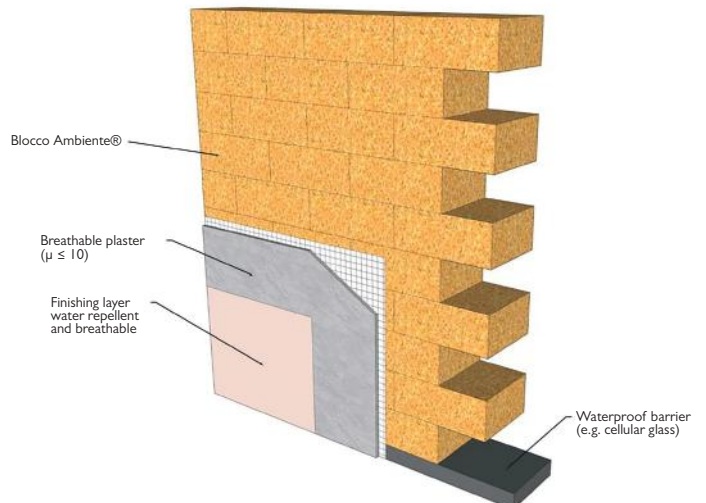
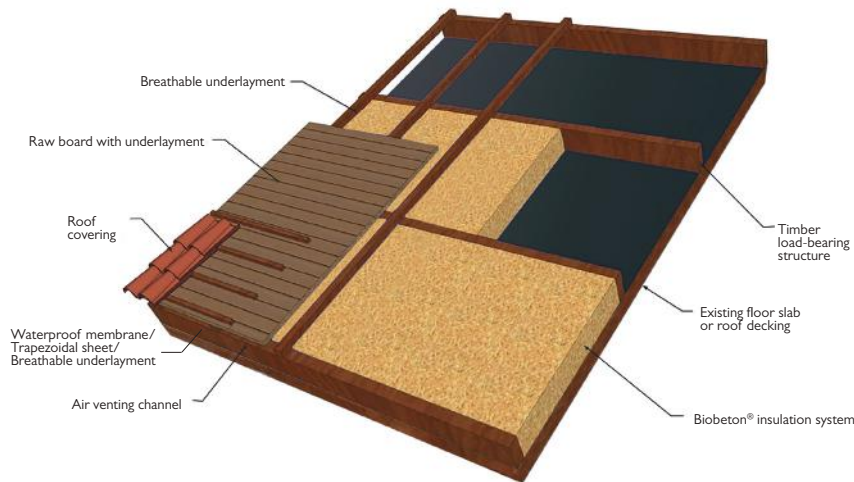
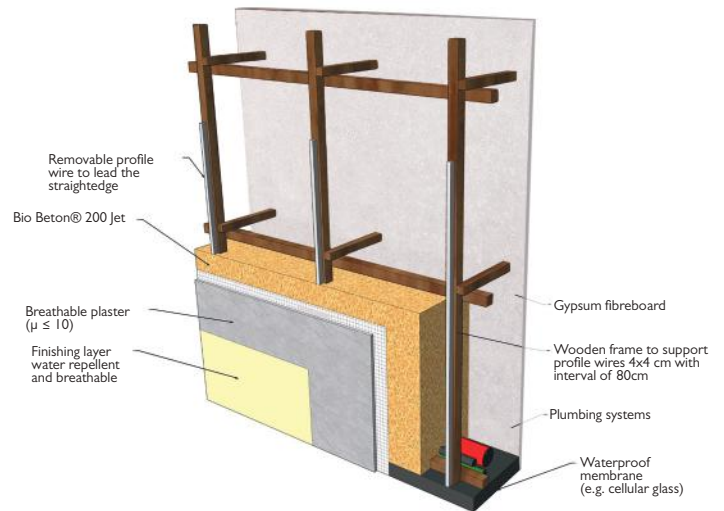



**Thermal
insulation**

ThermalInsulation

With the continuous succession of condensation and evaporation processes inside of Bio Beton® micropores, it is possible to block the passage of heat and cold from the outside to the inside of the building and vice versa.



**Thermal
mass**

ThermalMass

Thanks to the high specific weight, the material is able to accumulate heat and release it slowly with an effect similar to old houses made of stone i.e. cool in summer and warm in winter.



Breathability

Breathability

Bio Beton® works like a lung by regulating humidity. It absorbs excess humidity and releases it when the air is too dry: as if it was a humidifier / dehumidifier.



**Absence of
condensation**

Absence of condensation

Bio Beton® allows the passage of water vapour ensuring a healthy living environment and excellent air quality.



Wall Solutions



A_BloccoAmbiente® and BioBeton®200 Jet

25cm of Bio Beton® 200 Spray (0,053 W/mqK) on the internal surface of Blocco Ambiente® 12cm (0,07 W/mqK), completed with a coating cycle on both internal and external surfaces (2cm base coat + about 4mm skim coat), giving the following performing features:

WALL THICKNESS 41CM **TRANSMITTANCE $U=0,150$ W/m²K** **DECREMENT DELAY >21H**
(U-VALUE)

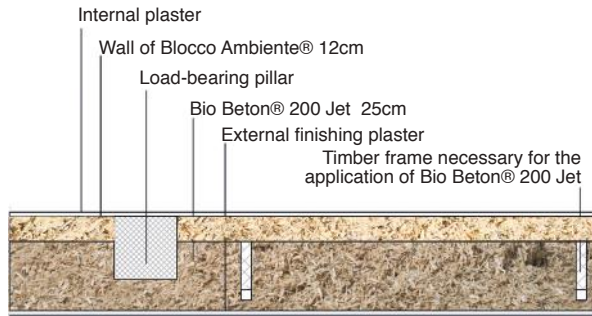

Plus:

- Total hemp solution = total green
- High thermal insulation = max winter comfort
- High thermal decrement delay = max summer comfort
- Total homogeneity of materials (single body)
- Installation of every system before spraying (no traces)

B_GypsumFibreboard and BioBeton®200 Jet

35cm of Bio Beton® 200 Spray (0,053 W/mqK) on the internal surface of gypsum fibreboards, completed with a coating cycle on the external side (2cm base coat + about 4mm skim coat), giving the following performing features:

WALL THICKNESS 39CM **TRANSMITTANCE $U=0,146$ W/m²K** **DECREMENT DELAY >18H**
(U-VALUE)

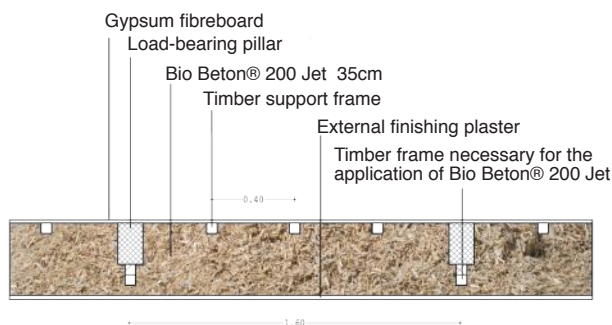

Plus:

- Total eco solution
- Dry laying of the fibreboards
- Installation of every system before spraying (no traces)
- Internal wall with great mechanical resistance
- High thermal insulation = max winter comfort
- High thermal decrement delay = max summer comfort



C_Clay Block and BioBeton®200 Jet

30cm of Bio Beton® 200 Spray 200 (0,053 W/mqK) on the internal wall of clay blocks P800 of 12cm, completed with a coating cycle on both internal and external surfaces (2cm base coat + about 4mm skim coat), giving the following performing features:

WALL THICKNESS 46CM **TRANSMITTANCE $U=0,154 \text{ W/m}^2\text{K}$** **DECREMENT DELAY >21 H**
(U-VALUE)

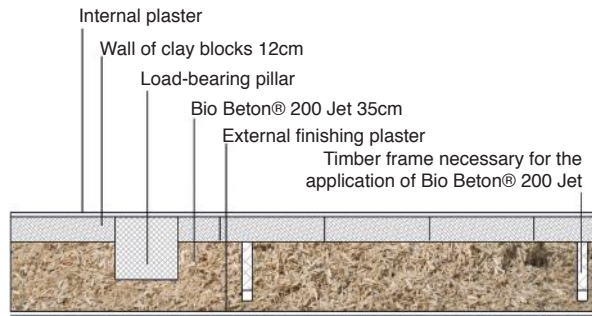

Plus:

- Total eco solution
- Installation of every system before spraying (no traces)
- Internal wall with great mechanical resistance
- High thermal insulation = max winter comfort
- High thermal decrement delay = max summer comfort

D_BloccoAmbiente® and filling of BioBeton®200 Pronto

12cm of Blocco Ambiente® internally (0,07 W/mqK), 8cm of Blocco Ambiente® externally (0,07 W/mqK), filling with 20cm of Bio Beton® 200 premixed, completed with a coating cycle on both internal and external surfaces (2cm base coat + about 4mm skim coat), giving the following performing features:

WALL THICKNESS 44CM **TRANSMITTANCE $U=0,146 \text{ W/m}^2\text{K}$** **DECREMENT DELAY >24 H**
(U-VALUE)

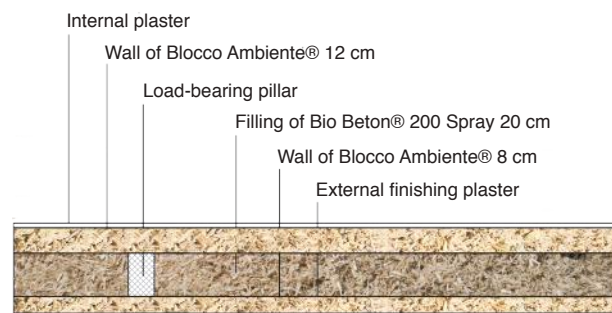

Plus:

- Total eco solution
- Installation of every system before spraying (no traces)
- Total homogeneity of materials (single body)
- High thermal insulation = max winter comfort
- High thermal decrement delay = max summer comfort

Further customised solutions can be the installation of Bio Beton® on:

- Reed walls with breathable plaster
- rammed earth panels with earth finish
- Exposed brick, stone, perforated bricks.

Roof:



Breathable **Roof** Highly **Insulated**

Wooden decking, cast of Bio Beton® 200 (0,053 W / smK), air venting channel and roof covering:

TRANSMITTANCE U = 0,146 W/M²K
DECREMENT DELAY > 24 HOURS

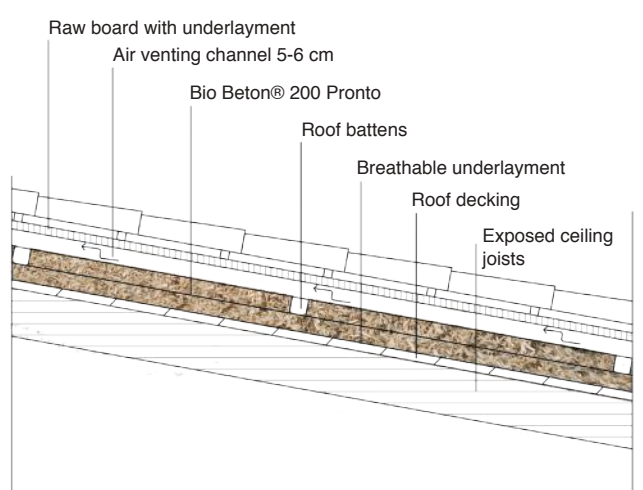

Plus:

- Total green solution
- High thermal insulation = maximum winter comfort
- High thermal decrement delay = max summer comfort
- Installation speed
- Total breathability = high interior comfort



Material Finish:



As an alternative to the traditional lime and inert mineral finishes (ICN Intonaco di Calce Naturale, SNT + Stabilitura Naturale Traspirante Plus), the masonry of Blocco Ambiente® or Bio Beton® 200 can be finished both inside and outside with Bio Beton® 500 'Venezia', a material finish composed of Thin Hemp Shiv, Natural Dolomitic Binder LDN and Effective Microorganisms.



Load-Bearing Structure

Timber frame. For a light but strong house.

The solutions for the building envelope presented in this catalogue match perfectly with all types of load-bearing frame proposed in the building market: reinforced concrete, steel and wood.

As an ideal solution from a technical point of view, it also suits the green building philosophy. Tecnocanapa by Senini recommends the timber load-bearing structure typically called “platform frame”. Just as hemp, wood also removes carbon dioxide from the environment during its life cycle.

From a technical and constructive point of view, the platform-frame solution allows to carry out timber frames that are rigid and anti-seismic. With ease and speed of installation it adapts to any architectural solution. They are used both for new buildings and for extensions or elevations. Finally, the timber load-bearing structure, having a specific weight similar to Bio Beton®, makes it possible to create buildings that are much lighter than traditional ones, allowing a reduction in the sizing of foundations with a reduction in reinforced concrete and unnecessary costs.





Mechanical systems

Only the Necessary for comfort

A building made with Bio Beton® allows the building envelope to reach high thermal performance with minimal heat loss, and excellent living comfort throughout the year. The heat requirement necessary to achieve interior comfort in the coldest weeks of winter or in the hottest weeks of summer is reduced to a minimum. This means that the energy required for heating and cooling is very low. Traditional systems that are designed to work with a lot of energy and for a long time, are therefore useless and excessively expensive. That's why passive houses typically use a Heat Recovery Ventilator system (HRV) to fight against the humid climate of some regions. This system is affordable and easy to install if designed from the start. It ensures the necessary air flow without heat loss, dehumidifies when necessary and if integrated with a heat pump, it performs the raising or lowering of the internal temperature, when required. By adding an electrical or heat pump system, with storage for domestic hot water, you can forget about gas!

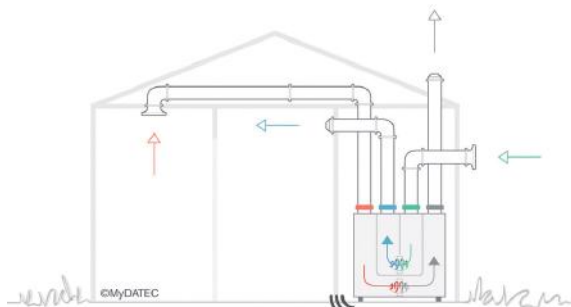

- Riscaldamento

- Ventilazione a doppio flusso

- Raffrescamento

- ACS

FASE 1

estrae
l'aria viziata da bagni e cucine (in media a 20°C).

recupera
il calore dall'aria estratta per poi trasferirlo all'aria nuova con un rendimento del 500% (COP pompa di calore maggiore di 5 alla temperatura esterna di -7°C).

Ora l'aria estratta è fredda: tutto il calore è stato prelevato e quindi MyDATEC la **espelle** all'esterno ad una temperatura tra 2 e 4°C.

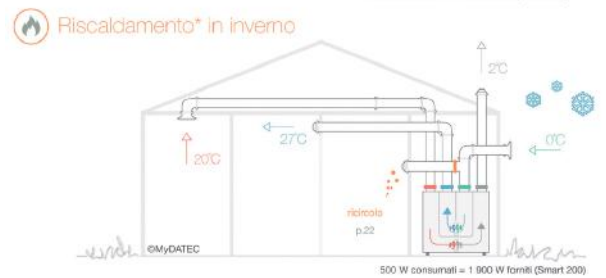
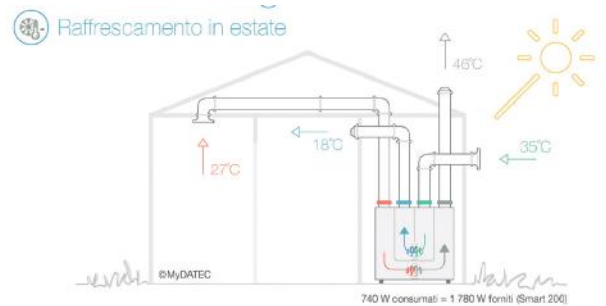

FASE 2

Aspira aria dall'esterno e **filtra** le impurità.

trasferisce all'aria esterna filtrata l'energia recuperata dall'aria estratta.

immette l'aria trattata (calda/fredda) nei locali per raggiungere la temperatura impostata dal termostato.

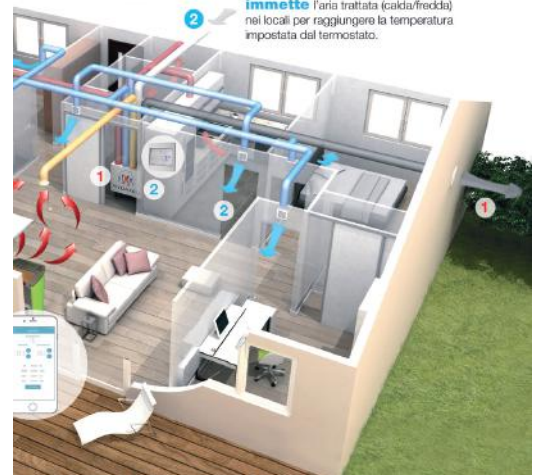

Fenestration

High performance windows and patio doors

By installing insulated monoblock counter frames, the installation of the fenestration will be very simple and quick. To live up to the performance of the building envelope of hemp-and-lime Bio Beton®, the fenestration must also have high thermal insulation performance.

We recommend the use of wooden or wood-aluminium frames with double or triple-glazed windows, for a total U_w less than or equal to $1 \text{ W/m}^2\text{K}$.

Alternatively, pvc frames also offer high-quality solutions.



The costs

The costs shown hereunder are expressed per square meter and valid for commercial buildings, and single-family or semi-detached residential buildings of approximately 200 sqm .

Building envelope **Tecnocanapa** by **Senini BioBeton**®

- **Roofing and wall systems,**
including monoblocks:

230-270 €/mq

- **Timber load-bearing structure,**
“platform frame” with floor slabs and roof:

260-330 €/mq

- **HRV and DHW systems,**
Heat Recovery Ventilator with integrated heat pump
necessary for heating and cooling. Domestic Hot Water
system with storage tank:

70-100 €/mq

- **Wood or pvc window frames**
High-performance wooden or pvc window frames:

90-120 €/mq

Total:

650-820 €/mq







SENINI POSE - Via Erculiani 164 - 25018 Novagli di Montichiari - BS
Centralino: 030 9665911 - tecnocanapa@senini.it
www.tecnocanapa-bioedilizia.it

MADE IN THE BEAUTIFUL ITALY